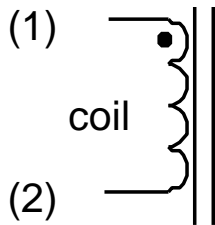

Table 1: Electrical Specifications at 25 °C.

PARAMETER	SPECIFICATION LIMITS			UNITS
	MIN	TYP	MAX.	
Coil 1 Inductance (1—2) 250mVrms @ 100 KHz	75	-----	-----	μH
Design Parameters: Switching Frequency	-----	60 to 400	-----	Hz
DCR (MAX) Coil 1 (1-2)	-----	-----	10	mO

Figure 1: Schematic Diagram



Note:

1. All materials meet UL94V-0 and are non-flammable.
2. All materials rated 130° C.
3. Dimensions in inch, .XX±0.03.
4. All hipot voltage are AC VOLTS RMS specified below at 60 Hz.
The leakage current doesn't exceed 60 μA rms.
1500V mini from (1&2) with respect to core.

Figure 2: Physical Dimensions in inch

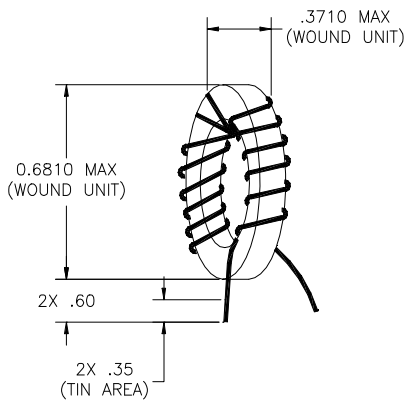

Figure 3: Inductor foot print.

